

## APPLICATIONS

Specially designed for air or mixed whirlpool systems

## TECHNICAL FEATURES

- Make low noise : <69.5dBa to 50 mBar
- 4 silent blocks included ("neoprene")
- Protection class II
- Grooved or to be stuck outlet fittings
- IP X5 in horizontal position

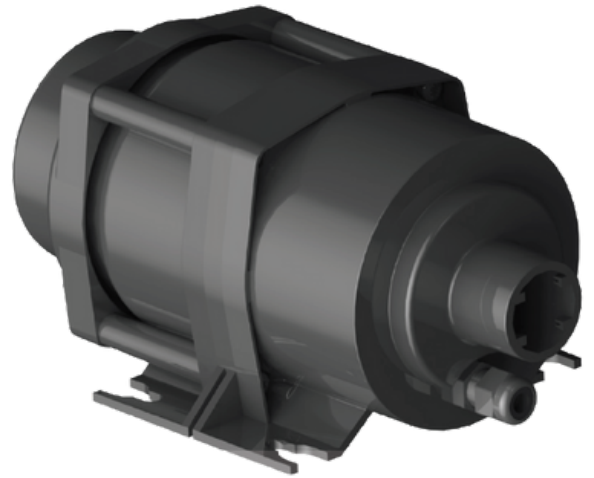

Type	Motor	Total power
Blower H-220	220 W	220 W

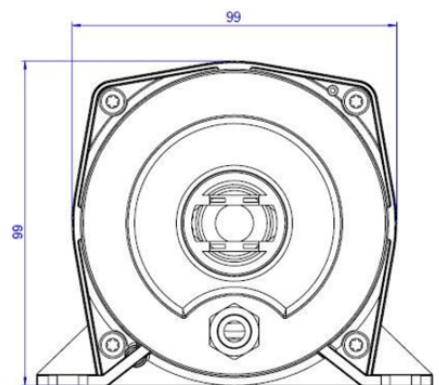
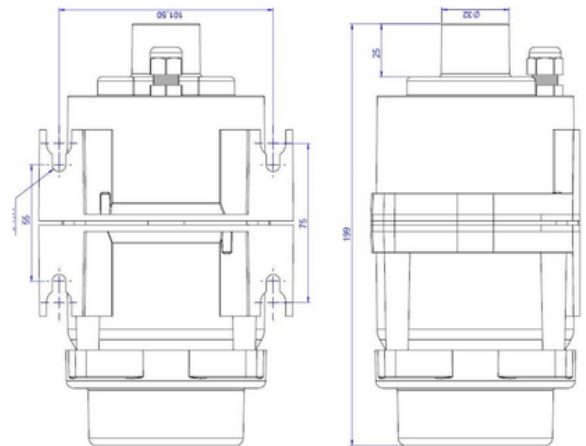
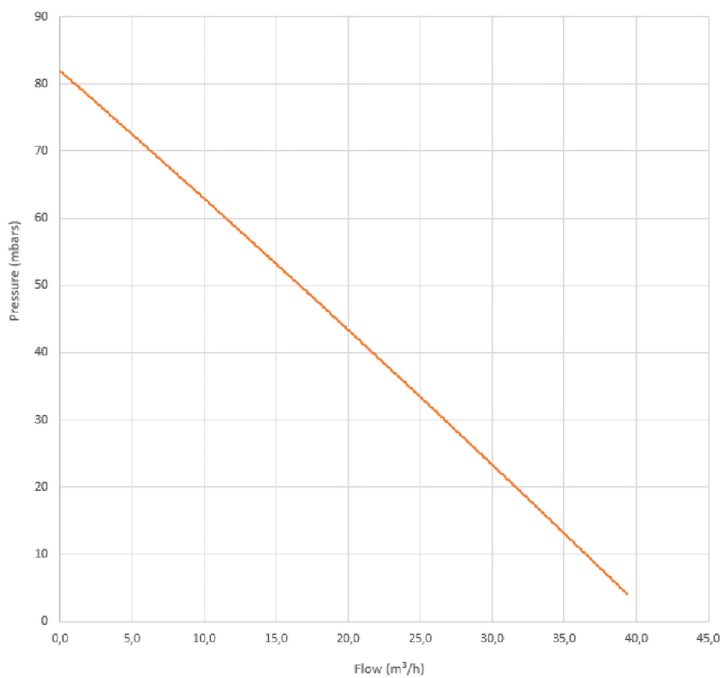

### General :

These blowers comply with the standards and directives in force  
 Conform to standards  
 EN 60 335 - 1  
 EN 60 335 - 2 - 41  
 According to the CE regulation