

APPLICATIONS

Pump for whirlpool baths and showers

TECHNICAL FEATURES

- Pump body in polypropylene
- Insulation class 1
- Complete draining (0 retention)
- Complete electric isolation on the driving shaft sleeve



Type	Electric power (W)	Pmax (bar)	Max flow (m ³ /h)	Pmin (bar)
ATL3 460 R	460	0.72	14.4	0.13
ATL3 560 R	560	0.85	16.8	0.21
ATL3 900 R	860	1.09	21.6	0.33

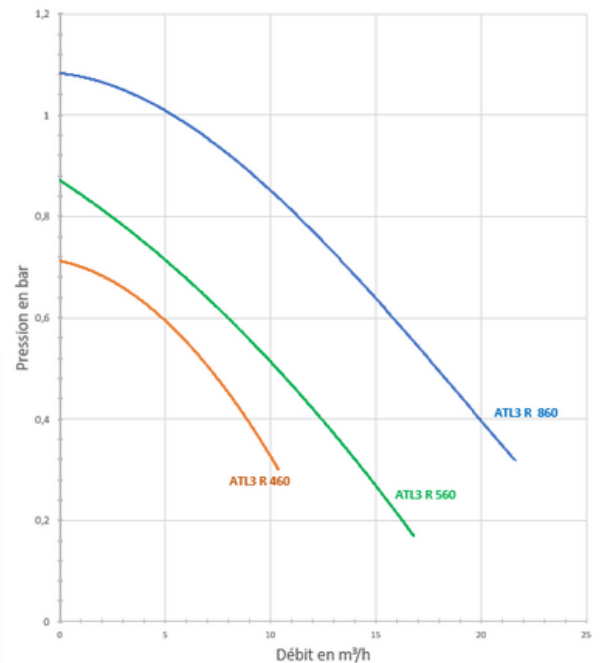
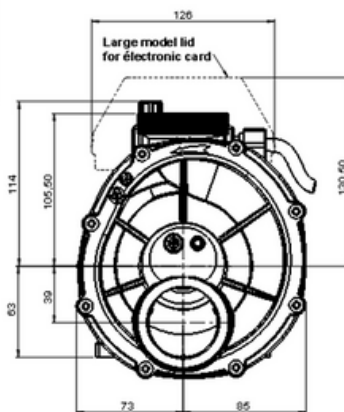
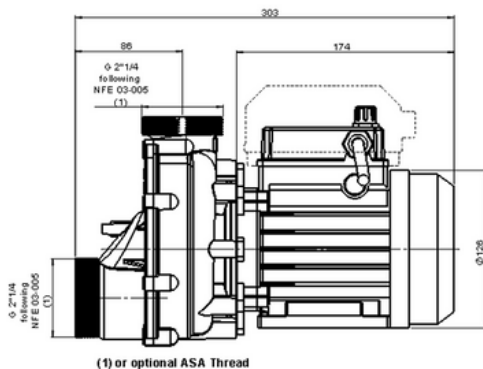

Options :

- 230 V / 50 Hz ou 220 V / 60 Hz ou 110 V / 60 Hz
- Pneumatic switch (CP)
- Electric cable (EC) 0.5 / 1 / 1.5 / 2 / 2.5m
- Double switch

General :

These pumps comply with the standards and directives in force
Conform to standards
EN 60 335 - 1
EN 60 335 - 2 - 41
CE